

ColorDesk  
**photo**

**User's Guide**

## Contents

3	Introduction
3	Product Overview
4	Installing ColorDesk Photo
5	ColorDesk Setup
6	Opening an Image
7	Suggested Work Flow
8	Geometric Corrections
9	Dust & Scratch Removal
9	Sharpening
9	AutoFinish
10	Color Corrections
12	MultiChoice
12	Edit by Reference
13	Saving and Inserting
15	Printing

### Software License Agreement

BY USING THIS PACKAGE, YOU ACCEPT ALL THE TERMS AND CONDITIONS OF THIS LICENSE AGREEMENT. If you do not agree to the terms of this Agreement, you should promptly return this package unopened to the place where you obtained it for a full refund.

Licenses: ColorDesk Inc. ("ColorDesk") grants you a license to use the enclosed application software, whether on compact disc or other diskettes ("Disks"), including the related documentation (the "Software") in accordance with the terms of this License. You own the Disk(s) on which the Software is recorded but ColorDesk and/or ColorDesk's Licensor(s) retain title to the Software.

You May: (1) use the Software on any single computer provided that the Software is in use on only one computer at a time. The Software is "in use" on a computer when it is loaded into the temporary memory (i.e., RAM) or installed into the permanent memory (i.e., hard disk) of that computer. (2) make a single copy of the Software solely for backup purposes. (3) use the Software in a networked environment so long as each computer in such environment is the subject of a separate license for the Software; however, you may not electronically transmit the Software from one computer to another over the network. (4) permanently transfer your rights under this Agreement to a third party by providing to such party this Agreement, the Software, and all accompanying written materials, provided that you retain no copies of the Software or written materials and that the other party agrees to the terms of this License Agreement.

You May Not: (1) make (or allow anyone else to make) any form of copy, whether digital, printed, photographic or otherwise, of any of the images in the Software, except insofar as such images may be incorporated by you into on-screen or printed material. (2) place (or allow anyone else to place) any of the images in the Software on an electronic bulletin board or other form of on-line service. (3) use (or allow anyone else to use) any of the images in the Software in any matter which is in any way defamatory of any person or business entity in any such image, or which implies any form of endorsement by ColorDesk, its suppliers, its licensors, or any individual or entity depicted in these images. (4) reverse engineer, decompile or disassemble the Software or otherwise reduce the Software to a human-readable form. (5) modify, adopt, translate, rent, lease, loan or create derivative works from the Software. (6) export the

Software in any form in violation of the United States Export Administration Act or the laws and regulations of any foreign jurisdiction.

Terms: This License shall continue for as long as you use the software, except that it will terminate if you fail to comply with any term or condition of this Agreement. Upon such termination, or in order for you to terminate the Agreement, you agree to destroy the original and any copies of the Software. The Limitation of Warranties and Liability set out below shall continue in force even after any termination.

Warranty: ColorDesk warrants to you that the Disk on which the Software is recorded will be free from defects in materials and workmanship for a period of ninety (90) days from your date of receipt. If such a defect occurs, return it to the address below and ColorDesk will replace it for free.

Limitation of Warranties and Liability: Except for the express warranty above, THE SOFTWARE IS PROVIDED "AS IS" WITHOUT WARRANTY OF ANY KIND. COLORDESK AND ITS LICENSORS MAKE NO OTHER REPRESENTATIONS OR WARRANTIES AS TO THE SOFTWARE, EITHER EXPRESS OR IMPLIED, INCLUDING, BUT NOT LIMITED TO THE IMPLIED WARRANTIES OF MERCHANTABILITY AND FITNESS FOR A PARTICULAR PURPOSE. ColorDesk's aggregate liability, including that of ColorDesk's dealers, suppliers and licensors, shall not exceed the amount paid by you for the Software. IN NO EVENT WILL COLORDESK, ITS LICENSORS OR ITS DEVELOPERS, DIRECTORS, OFFICERS, EMPLOYEES OR AFFILIATES BE LIABLE FOR ANY CONSEQUENTIAL, INCIDENTAL OR INDIRECT DAMAGES (INCLUDING BUT NOT LIMITED TO DAMAGES FOR LOSS OF BUSINESS PROFITS, BUSINESS INTERRUPTION AND LOSS OF BUSINESS INFORMATION) ARISING FROM THE USE OF OR INABILITY TO USE THE SOFTWARE OR ACCOMPANYING WRITTEN MATERIALS. Some states do not allow the exclusion or limitation of liability for consequential or incidental damages, so the above limitation may not apply to you.

Restricted Rights: Use, duplication or disclosure by the Government is subject to restrictions as set forth in subdivision (c)(1)(ii) of the Rights in Technical Data and Computer Software clause of DFARS 252.227-7013.

General: You acknowledge that you have read this Agreement and understand that it is the complete and exclusive statement of your agreement with ColorDesk Inc. This Agreement will be governed by the laws of the State of California.

## Notice

All rights reserved. No part of this publication may be reproduced, stored in a retrieval system, or transmitted, in any form or by any means, electronic, mechanical, photocopied, recorded, or otherwise, without prior written permission from ColorDesk, Inc.

## Trademarks

ColorDesk Photo, ColorDesk and the ColorDesk logo are trademarks of ColorDesk, Inc. EfiColor is a trademark of Electronics for Imaging, Inc. All other product names, company names and brand names are trademarks or registered tradenames of their respective companies.

## Introduction

Congratulations on your purchase of **ColorDesk Photo 1.0!** High quality, color photo editing and printing is now within the reach of your desktop. **ColorDesk Photo** allows you to easily add sharp, color photos to your reports, newsletters, flyers, presentations, brochures and other documents. Whether you're using a hand-held scanner and ink jet printer at home, a flatbed scanner, Photo CD and high-end printer at work, or your local print shop's equipment, ColorDesk Photo gives you the precise, professional results you want. And its easier than using your favorite word processor!

If you haven't already taken the time, please be sure to fill out and send in your product registration card today. This information allows us to provide you with the best technical support while keeping you informed of valuable product and upgrade information.

## Product Overview

**ColorDesk Photo** is a complete desktop color photo publishing system which provides a simple way to capture color images on your Microsoft Windows PC, easily add them to your documents and print them with high quality results on almost any color printer. With no expert knowledge of the color publishing process required, anyone can now edit and print professional-looking, color documents utilizing advanced technology previously available only to the pre-press industry.

**ColorDesk Photo** provides you with many of the capabilities of a photo touch-up lab. Rotation, cropping, resizing and flipping can all be done at the click of a button. Tools for dust and scratch removal and image sharpening give you the ability to overcome imperfections in the original photograph. Color enhancement tools allow you to adjust exposure, color balance, highlights, shadows, contrast and more.

In short, you can do the work that is normally done by a skilled graphic arts technician with a complex color separation scanner. But you can do it on your PC using simple editing tools.

More importantly, you don't have to know anything about color processing or printing. **ColorDesk Photo** makes the process intuitive and easy while handling much of the complexity itself.

At the heart of **ColorDesk Photo** is the ColorDesk Color Matching System. An enhanced version of the industry-proven, EfiColor Color Management System, the system provides precise color matching across all your desktop color peripherals. Images and photographs from your scanner, Photo CD, digital camera or any image bank are accurately reproduced across all supported displays and printers.

The results are WYSIWYG in its truest form – **WHAT YOU SEE** on your screen **IS** exactly **WHAT YOU GET** from your printer. No more “print-compare-edit-reprint” trial and error cycles, wasting paper, ink and your precious time. If you like what you see on the screen, you'll like what you get from the printer.

**ColorDesk Photo** also provides support for OLE 2.0 allowing you to access all these capabilities without ever leaving your favorite Windows application such as Microsoft Word, PowerPoint or WordPerfect.

You can even make changes to your image and have it reflected in all documents containing a link to it.

## Installing ColorDesk Photo

### *Requirements:*

To successfully run **ColorDesk Photo**, you should have the following:

- IBM-compatible PC with 386 CPU or higher
- 4 MB of RAM (8 MB recommended)
- 5 MB disk space
- Graphic display system capable of at least 256 colors
- Microsoft Windows 3.1 or higher

### *To Install*

Installing **ColorDesk Photo** is easy. Just follow these steps:

1. Run Microsoft Windows.
2. Insert diskette #1 in floppy disk drive A.
3. In Program Manager, select the **Run** command from the File menu.
4. Type **a:setup** and press **OK**.

During installation, you will be prompted for the directory in which to install **ColorDesk Photo**. Press ENTER to use the default directory, or type in your desired directory. The installation program will then prompt you to insert the next diskette into the disk drive.

When the installation is completed, the **ColorDesk Photo** application

icon  appears in the ColorDesk Program Group .

To verify the installation, double-click the **ColorDesk Photo** icon to start the application.

## ColorDesk Setup

To enable accurate color matching, click the ColorDesk button to specify the peripheral devices you are using: scanner, monitor, printer. Change these settings whenever you want to specify a different device.



1. Click the ColorDesk button.



2. For each device category, click the Down Arrow to display the list of peripherals. There may be more than one listing for any given brand of peripheral. For printers, the settings include different paper types. Make sure to choose your exact brand and model.

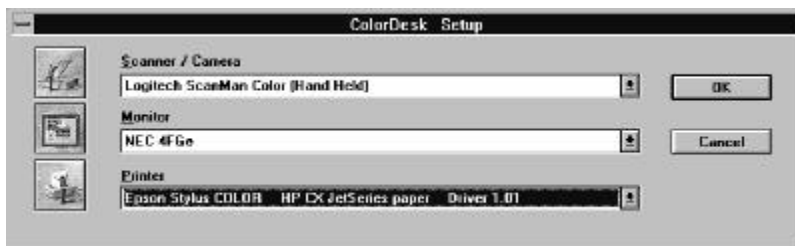

3. Select the scanner, monitor and printer you are working with. If your peripheral is not listed, select "other".
4. Click OK.
5. In order to achieve accurate color matching, it is important to make sure that the driver settings for your scanner and printer are set correctly. You can find the correct settings for your scanner and printer in the on-line help, under Driver Settings. To check the current printer settings and modify them if necessary, select Print Setup from the File menu, and click the Options button. To check the current scanner settings and modify them if necessary, select Acquire from the File menu.

### **Note**

If the paper you are using is not supported, choose a setting with a paper type of the same family - coated, glossy, plain, etc.

## Opening an Image

ColorDesk Photo enables you to open image files created by different input sources, in a variety of image file formats. You can open multiple images at the same time.



### **To Scan an Image**

Use the Select Source option in the File menu to specify the scanner type, and then click the Scan button . To achieve good color matching, make sure you have specified the correct scanner type, as described on the previous page.

### **To Load a CD Image**

Click the Load CD button . If your CD is a Photo CD, a standard Photo CD browser with thumbnail images appears. Otherwise, a standard Windows File Open dialog box appears, describing your CD content.

### **To Open an Image File**

Click the Open File button , and specify the file you want to open.

### **To Open Special**

*Open an image file which was not originally scanned from ColorDesk Photo*

Use Open Special to open a file which was not scanned through **ColorDesk Photo** and for which you know its source, i.e. the scanner used. Select Open Special in the File menu. In the dialog box that appears, specify under Source Device the scanner used to create the file. If the image was originally scanned from **ColorDesk Photo**, open the image using the Open command; do not use Open Special.

## Suggested Work Flow

Enhancing photos is more effective if done in a specific order. The steps below represent the recommended work flow for performing these enhancements, however, you may perform these steps in any order that you find convenient. If a specific step is not required, skip it and go to the next step. Each of the individual steps is explained more fully in the following sections.

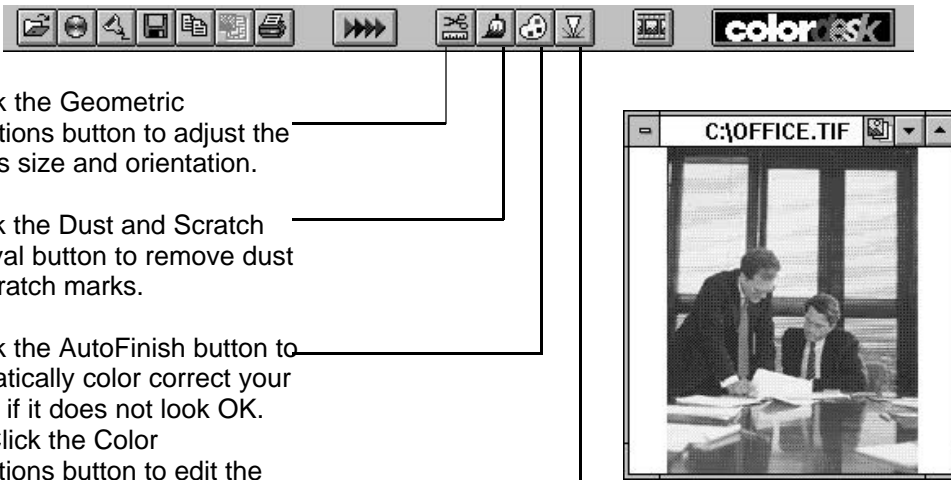

1. Click the Geometric Corrections button to adjust the image's size and orientation.

2. Click the Dust and Scratch Removal button to remove dust and scratch marks.

3. Click the AutoFinish button to automatically color correct your image, if it does not look OK.  
OR - Click the Color Corrections button to edit the image's colors. You can click the Reference Image Library button to help you edit your image by selecting an image for comparison.

4. Click the Sharpening button to give the image a crisper look.

After editing the image, you can drag and drop it into any OLE document (such as Microsoft Word), save it, or print it. Whatever you do, ColorDesk setup ensures the very best color output.

## Geometric Corrections

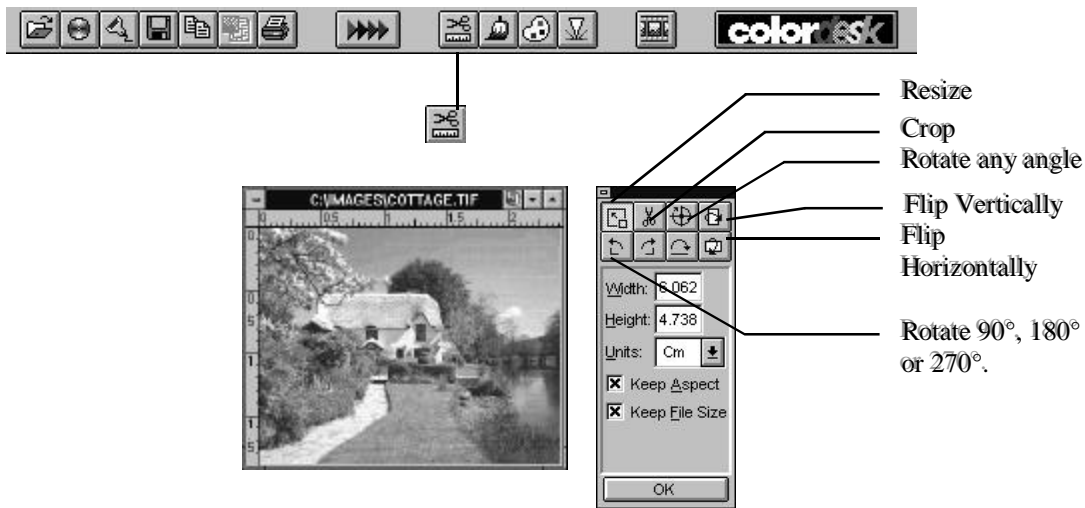

### **Resize**

Click the Resize button  , and type in the new width and height in the units you choose (inches or centimeters)

- or drag on the resize bars which appear on the image's borders. If you check the Keep Aspect option, the proportion of height to width in the resized image is automatically maintained as in the original image. Check the Keep File Size option if you want the resized file to still take up the same amount of disk space. This means that if you change the size of the image on screen, the resolution of the printed image will change accordingly.

### **Crop**

Click the Crop button  . In the crop dialog box, specify the Units, and enter the new height and width, or drag on the image to delineate the area to be saved.

### **Rotate Any angle**

Click the Rotate Any Angle button  . In the dialog box, specify the angle of rotation, or drag one of the horizontal or vertical grid lines to the desired rotational positions. If you want to straighten an image, drag one of the horizontal or vertical grid line to align it with a horizontal or vertical line of your image.

### **Rotate / Flip**

Use the other Rotate and Flip buttons to change the orientation of your image.

Rotate 90° to the left  Rotate 90° to the right  Rotate 180°  Flip horizontally  Flip vertically 

## Dust & Scratch Removal

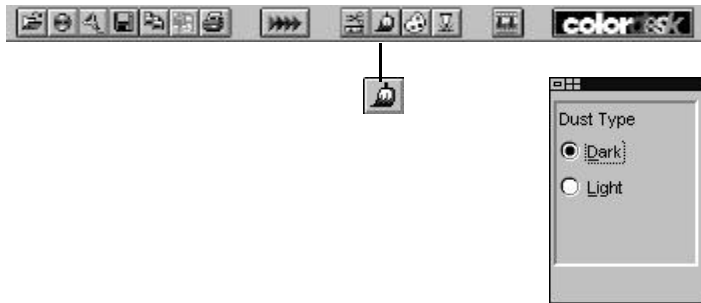

Click the Dust and Scratch Removal button. In the dialog box, select the dust or scratch type: a Dark scratch on a light background, or a Light scratch on a dark background. Click and drag to delineate the area surrounding the scratch. The scratch will fade into the background.

## Sharpening

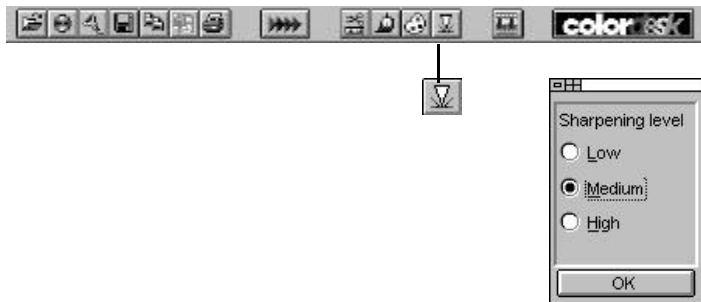

Click the Sharpening button to give the image a crisper look. In the dialog box, select the sharpening level: Low, Medium, or High.

## Auto Finish



Click the AutoFinish button if you want **ColorDesk Photo** to automatically color correct your image for you. A color correction toolbar appears, which displays the corrections made and lets you do further manual color corrections. To activate this toolbar without the automatic correction, click the Color Corrections button. Use AutoFinish only if your original image needs correcting.

## Color Corrections

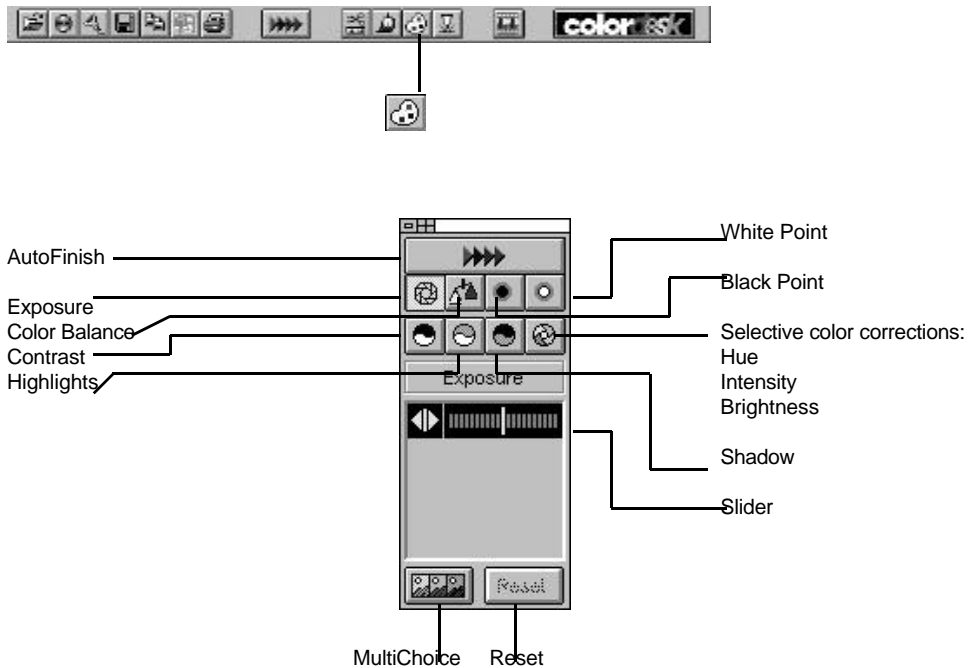

### ***How to use the slider***

To adjust settings using the slider, click the Right and Left Arrow buttons, or click directly on the slider to increase or decrease settings.

### ***Exposure***

To adjust exposure, click the Exposure button , and use the slider to adjust the amount of exposure.

### ***Color Balance***

Use Balance to adjust the overall tint of the image. When you click the Balance button, a colorful balloon appears in the dialog box. Drag the black handle in its center to shift color balance, or, in the image, click on the area that you wish to appear neutral (such as gray).

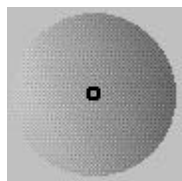

### ***Black Point***

Use Black Point to specify the darkest point in the image. After clicking the Black Point button, use the slider - or, click on the image's darkest location to set the Black Point.

### ***White Point***

Use White Point to specify the whitest point in the image. After clicking the White Point button, use the slider - or, click on the image's lightest location to set the White Point.

### ***Contrast***

To adjust contrast, click the Contrast button  , and use the slider.

### ***Highlights***

To adjust the brightness of lightest portions of the image, click the Highlights button  , and use the slider.

### ***Shadows***

To adjust the amount of detail in the shaded portions of the image, click the Shadows button  , and use the slider.

### ***Selective Color Corrections***

To correct the color attributes of an individual color or of all colors, click the Selective Color Corrections button. A color wheel and three buttons appear: one for Hue, one for Intensity and one for Brightness. Click inside the white center to edit all colors - or in an individual sector to edit that color. Then you can adjust the hue, intensity and brightness by clicking on the appropriate button and using the slider to adjust the settings.

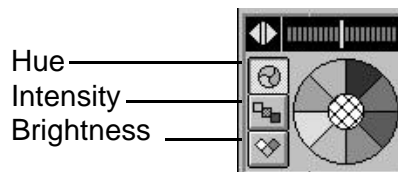

Please refer to On-Line Help for further details.

## MultiChoice

Use MultiChoice in conjunction with any of the ten Color Corrections tools to fine-tune your editing. Click the MultiChoice button after selecting a color tool, for example, Exposure. A window appears with a series of three images: the middle one shows the current image, the left one shows the image with exposure at one level lower (-1), and the right one shows the image with exposure at one level higher (+1). Clicking the right or left image moves that image to the current (middle) placement, with new corresponding (-1) and (+1) images. The working image and the tools' sliders are updated as well.



## Edit By Reference

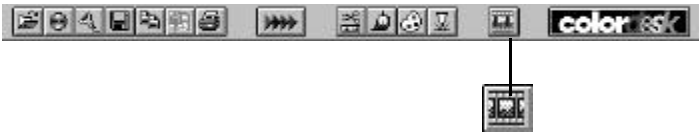

What do you do if you cannot decide how your image looks best? Use **ColorDesk Photo's** library of reference images. Select a reference image, and set it beside your own image. Then adjust your image, until its color and lighting properties are similar to the reference image. Click the Reference Image Library button.

In the drop down list, select a category that most closely matches the kind of image you have. Within each category, select from among the various images.

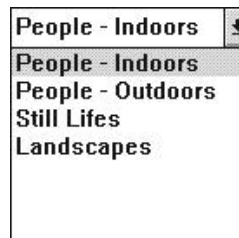

It is recommended to adjust your monitor using your monitor controls until you see the reference images at their best.

## Saving and Inserting

Now that you are finished editing your image, save it and insert it into your document. You can save an image in a variety of graphic file formats, and you can save it so that it can be correctly printed on a variety of printers.

1. Save the image, or
2. Save As, or
3. Save Special

4. Drag-and-Drop icon
5. Copy to Clipboard
6. Insert in other document

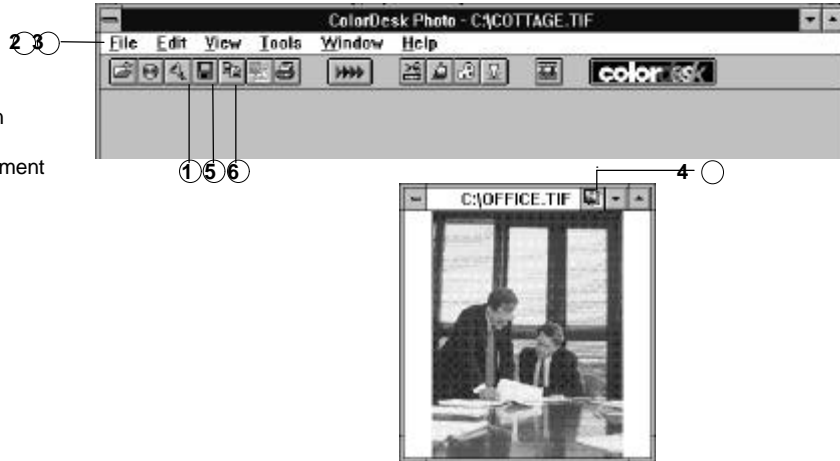

### Save

If your image is already associated with a disk file, click the Save button  , to save any changes you recently made.

### Save As

Select Save As from the File menu if you want to save your image to a disk file for the first time, or change its format, name or directory.

### Save Special

Use Save Special: a. To save your file if you are going to print it on a printer not currently connected to your computer or network. **ColorDesk Photo** saves the image with the correct color data for the specified printer. You can then print the image from any application that can handle the image. or b. To print the image from a non-OLE application ( an application into which **ColorDesk Photo** images cannot be inserted). Select Save Special from the File menu, enter the name and desired file format, and select the printer you will use from the Destination Device drop down menu. You can then open the image in the non-OLE application. It will print as if it was printed directly from **ColorDesk Photo**.

### Drag & Drop

Use drag-and-drop to embed your image in another OLE-compliant application. To drag-and-drop an image, both **ColorDesk Photo** and the other application should be visible on your computer screen. In **ColorDesk Photo**, press the left mouse button on the Drag-and-Drop icon in the title bar of the image, drag the image to the other document, and drop it at the point of insertion. Note that the shape of the cursor indicates where you can  or cannot drop the image.

Regardless of how the dropped image appears on the screen, its printing colors are matched to the image seen in **ColorDesk Photo**.

### ***Copy to Clipboard***

Another way to embed your image in another document is to copy it to the Clipboard, and then paste it in the other document. Use this when you cannot use drag-and-drop, either because its inconvenient to make both applications visible, or when the target application does not support drag-and-drop.

In **ColorDesk Photo**, click the Copy to Clipboard button. Then go to another Windows application, and paste the image into a document using the Paste Special command.

### ***Insert Object***

Some applications allow you to insert an image from **ColorDesk Photo** without leaving the application. In the application, place the position indicator at the point of insertion, and select the Insert Object command - which is in the Edit menu in Write, and in the Insert menu in Word. In the Insert Object dialog box, select **ColorDesk Photo** from the drop-down list. If **ColorDesk Photo** is not already running, this command will automatically initiate **ColorDesk Photo**. When you view the **ColorDesk Photo** window, you can open and edit an image file.

When you have the desired image, select the Exit and Return command from the **ColorDesk Photo** File menu. This will return you to the other application, and embed the **ColorDesk Photo** image in that application. Or, when you have the desired image, click the Insert button in the toolbar, or select the Insert command from the **ColorDesk Photo** File menu. This will embed the current image in the other application without leaving **ColorDesk Photo**.

You can edit an image inserted as an object by double-clicking on the image. If you are using Microsoft Word 6.0, the **ColorDesk Photo** icon appears at the toolbar. Clicking the icon is equivalent to the Insert Object command.

## Printing

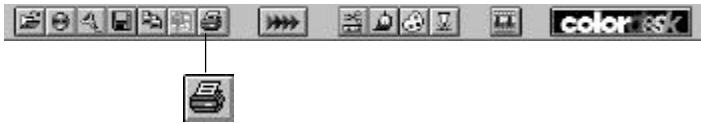

For best results, before printing, verify that you have specified the correct printer in ColorDesk Setup, and that the printer driver is set according to the settings found in the Online help under Driver Settings. If you cannot find a printer that is applicable in the ColorDesk Setup, select “other”.

If you want to change printer setup information, select the Print Setup command in the File menu, or click the Setup button in the Print dialog box.

### ***To print***

Click the Print button. In the Print dialog box enter the desired printing information. In general, you can use the defaults. Click OK.

### ***Printing an Embedded Image***

When images are embedded into the document application (called container), the images are setup to print with color matching to the printer specified at the time of insertion. If you will be printing on a different printer, double click the image when in the container application. **ColorDesk Photo** opens. Click the ColorDesk button, and select the desired printer. Then double click the upper left corner to close.